

**caroma<sup>®</sup> H<sub>2</sub>ZERO**

**cube<sup>3</sup>**

**Urinal**

**Vitreous China Wall-Hung Urinal**

CI/SfB	(74.1)	g3
Date	March 2010	

Supersedes all previous issues

**7.01.1**



# Cube Urinal

## Vitreous China Wall-Hung Urinal

**caroma**® **H<sub>2</sub>ZERO**



A contemporary design wall mounted urinal providing superior waterless technology for optimum water efficiency. The Caroma **H<sub>2</sub>Zero™ Cube** Urinal has been designed to utilise unique cartridge technology. The patented cartridge incorporates a Bio Seal™ that opens during usage and self seals immediately after use eliminating the need for flushing water. A replaceable Bio Fresh deodorising block maintains the aesthetics of the urinal bowl by assisting in the dissipation of uric salts and releasing a pleasant fragrance. The urinal incorporates concealed plumbing connections and easy to clean surfaces for minimum low cost maintenance. The metal grate is vandal resistant and a specially designed tool is used for the touch-free replacement of the Bio Seal™ and Bio Fresh deodorising block. Caroma **H<sub>2</sub>Zero™ Cube** Urinal Code No.678610.

- Trap:** The unique one way Bio Seal™ opens with usage and self seals immediately. This eliminates the need for flushing water.
- Outlet:** The urinal outlet is connected to 50mm PVC DWV waste pipe.
- Fixing:** The **H<sub>2</sub>Zero™ Cube** urinal is fixed to the wall with the D.167 Concealed Fixing Bracket supplied.
- Fittings:** Vandal resistant satin-chrome grate supplied as standard. Vitreous china grate option is available for light commercial applications. Code No.687080W
- Colours:** White only.
- Installation:** The urinal must be installed in accordance with the AS/NZS 3500 Plumbing requirements. Local Authorities have varying requirements.
- Dimensions:** All dimensions are in millimetres and are subject to normal manufacturing variations. Caroma pursues policy of continued improvement in design and performance of its products. The right is therefore reserved to vary specifications without notice.

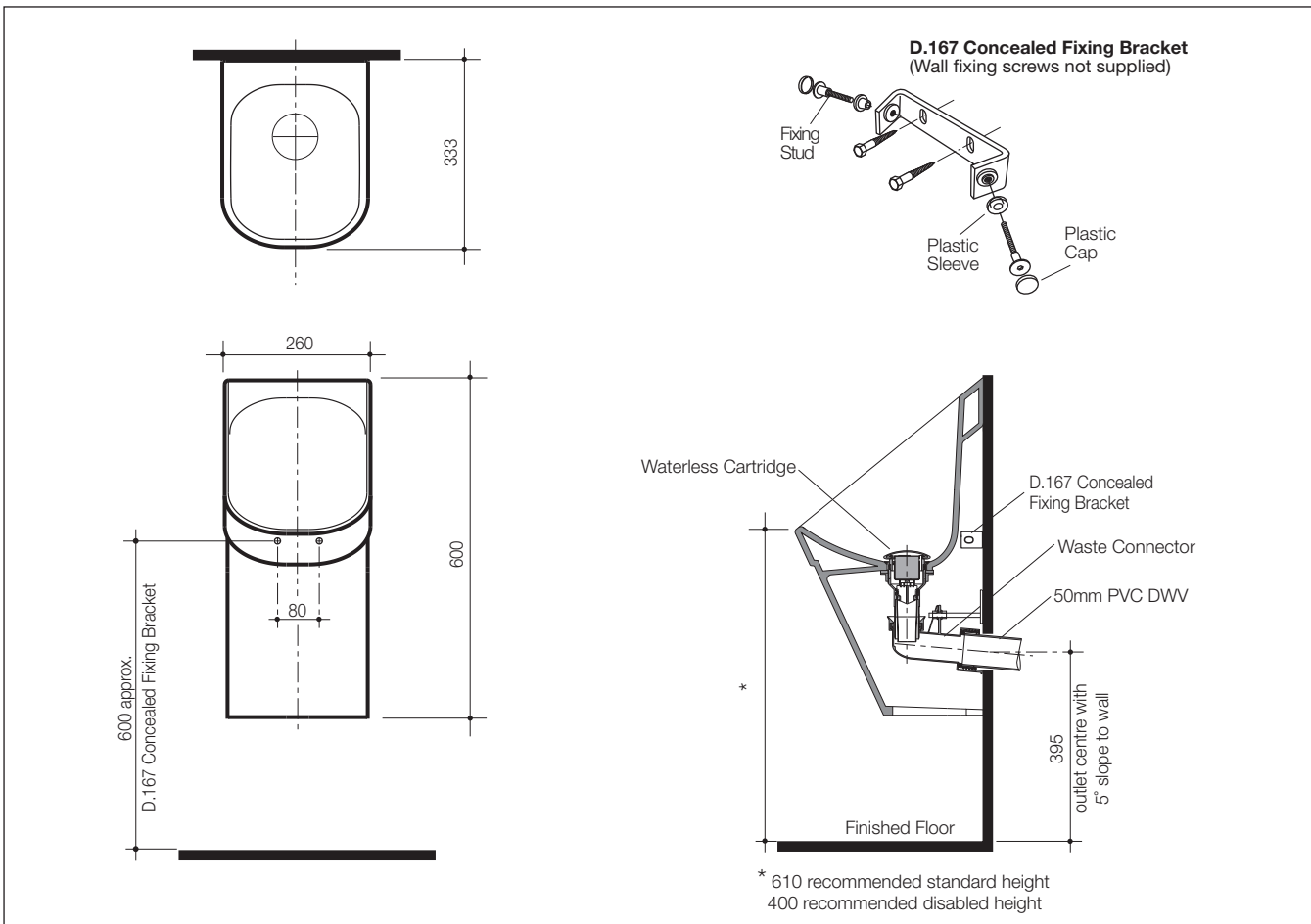

**H<sub>2</sub>Zero™ Cube Urinal Waste Outlet Installation Detail**

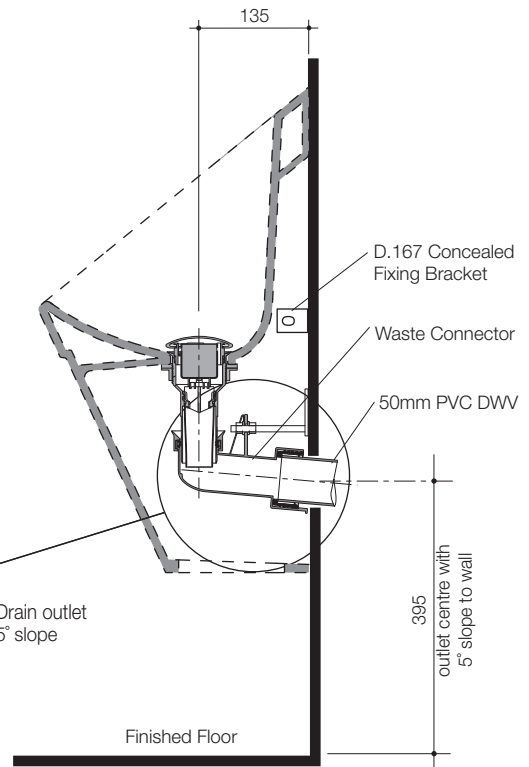
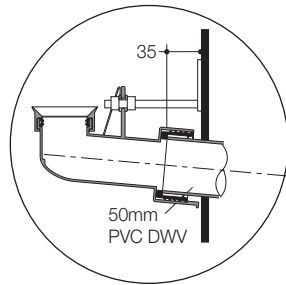
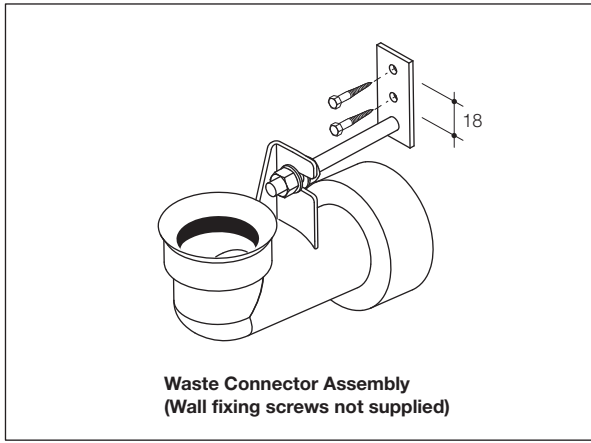

**H<sub>2</sub>Zero™ Cube Urinal Waterless Cartridge Installation Detail**

